

Sample Paper 2020-21

General instructions:

1. This question paper contains two parts A and B.
2. Both Part A and Part B have internal choices.

Part – A :

1. It consists of two sections – I and II
2. Section I has 16 questions. Internal choice is provided in 5 questions.
3. Section II has four case study-based questions. Each case study has 5 case-based sub-parts. You have to attempt any 4 out of 5 sub-parts.

Part – B:

1. It consists of three sections – III, IV and V
2. Question No 21 to 26 are Very short answer Type questions of questions 2 marks each.
3. Question No 27 to 33 are Short answer Type questions of 3 marks each.
4. Question No 34 to 36 are Long answer Type questions of 5 marks each.
5. Internal choice is provided in 2 questions of 2 marks, 2 questions of 3 marks and 1 question of 5 marks.

PART – A

Section – I

Section I has 16 questions of 1 mark each. Internal choice is provided in 5 questions.

1. Given that $\text{HCF}(2520, 6600) = 40$, $\text{LCM}(2520, 6600) = 252 \times k$, then find the value of k.

OR

The decimal representation of $\frac{14587}{2^1 \times 5^4}$ will terminate after how many decimal places?

2. If one zero of the quadratic polynomial $4x^2 - 8kx - 9$ is negative of the other, find the value of k.
3. Find the value of k for which the system of equations $kx + 2y = 5$, $3x + y = 1$ has unique solution?
4. If $x = a$, $y = b$, is the solution of the systems of equations $x - y = 2$ and $x + y = 4$ then find the values of a and b.
5. Find the sum of first 16 terms of the AP: 10, 6, 2,.....

OR

The first term of an AP is -7 and the common difference is 5. Find its general term.

6. If one root of the quadratic equation $2x^2 + kx - 6 = 0$ is 2, find the value of k.
7. Solve the Quadratic equation $\sqrt{3}x^2 + 10x + 7\sqrt{3} = 0$.

OR

Find the value of k for which the equation $2kx^2 - 40x + 25 = 0$ has equal roots.



8. In the figure PA and PB are tangents to a circle with centre O. If $\angle AOB = 120^\circ$, then find $\angle OPA$.

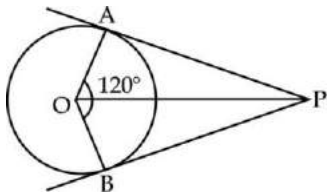

OR

If angle between two radii of a circle is 130° , find the angle between the tangents at the ends of the radii.

9. In the figure, QR is a common tangent to the given circles touching externally at the point T. The tangent at T meets QR at P. If $PT = 3.8$ cm, then find the length of QR.

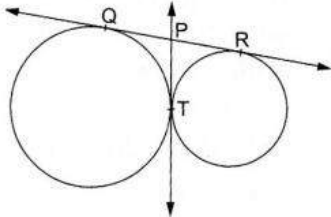

10. In $\triangle ABC$, D and E are points on the sides AB and AC respectively such that $DE \parallel BC$. If $AD = 4x - 3$, $AE = 8x - 7$, $BD = 3x - 1$ and $CE = 5x - 3$, find the value of x.
11. A tangent PQ at a point P of a circle of radius 5 cm meets a line through the center O at a point Q so that $OQ = 12$ cm. Find the length of PQ.
12. If $\tan \alpha = \frac{1}{\sqrt{3}}$ and $\sin \beta = \frac{1}{\sqrt{2}}$, find $\alpha + \beta$.
13. If $\sec^2 \theta (1 + \sin \theta) (1 - \sin \theta) = k$, then find k.
14. In a circle of diameter 42 cm, if an arc subtends an angle of 60° at the center where $\pi = \frac{22}{7}$, find the length of the arc.
15. 12 solid spheres of the same radii are made by melting a solid metallic cylinder of base diameter 2 cm and height 16 cm. Find the diameter of each sphere.
16. If a die is thrown once. Find the probability of getting a prime number.

OR

From a well shuffled pack of cards, a card is drawn at random. Find the probability of getting a black queen.

Section-II

Case study based questions are compulsory. Attempt any four sub parts of each question. Each subpart carries 1 mark.



Case study based -1
CARTESIAN PLANE

17. Using Cartesian Coordinates we mark a point on a graph by how far along and how far up it is. The left –right (horizontal) direction is commonly called X-axis. The up-down (vertical) direction is commonly called Y-axis. When we include negative values, the x and y axes divide the space up into 4 pieces. Read the following passage and answer the questions that follow the above information:

In a classroom, four students Sitha, Gita, Rita and Anita are sitting at A (3,4), B (6,7), C (9,4), D (6,1) respectively. Then a new student Anjali joins the class.

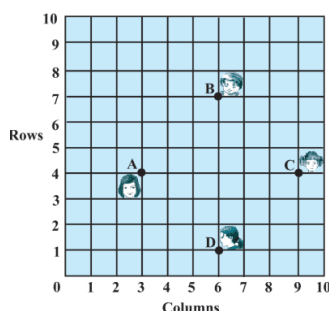

- i) Teacher tells Anjali to sit in the middle of the four students. Find the co-ordinates of the position where she sits.
 - a. (2,4)
 - b. (4,4)
 - c. (6,4)
 - d. (6,5)
- ii) The distance between Sita and Anita is
 - a. $3\sqrt{3}$ units.
 - b. $3\sqrt{2}$ units.
 - c. $2\sqrt{3}$ units.
 - d. $3\sqrt{5}$ units.
- iii) Which two students are equidistant from Gita?
 - a. Anjali and Anita
 - b. Anita and Rita
 - c. Sita and Anita
 - d. Sita and Rita
- iv) The geometrical figure formed after joining the ABCD is a
 - a. Square
 - b. Rectangle
 - c. Parallelogram
 - d. Rhombus
- v) The distance between Sita and Rita is
 - a. 4 units
 - b. 6 units
 - c. 5 units
 - d. 7 units

18. **Case study based -2**

SIMILARITY OF TRIANGLES

Teacher gives an activity to the students to measure the height of the tree and asks them who will do this activity. Anjali accepts the challenge. She places a mirror on level ground to determine the height of a tree. She stands at a certain distance so that she can see the top of the tree reflected from the mirror. Anjali's eye level is 1.8 m above the ground. The distance of Anjali and the tree from the mirror are 1.5 m and 2.5 m respectively. Answer the questions below.

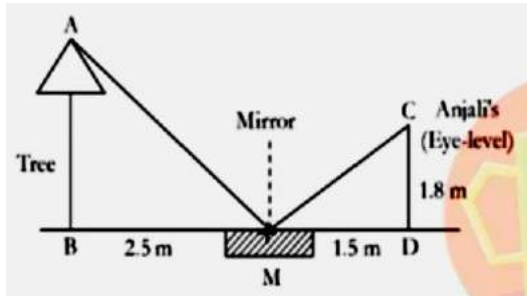

- i) Name the two similar triangles formed.
 - a. $\Delta ABM \sim \Delta CMD$
 - b. $\Delta AMB \sim \Delta CDM$
 - c. $\Delta ABM \sim \Delta MDC$
 - d. None of these
- ii) State the criteria of similarity that is applicable here.
 - a. SSS Criterion
 - b. SAS Criterion
 - c. AA Criterion
 - d. ASA Criterion
- iii) Find the height of the tree.
 - a. 3 m
 - b. 3.5 m
 - c. 2.5 m
 - d. 4 m
- iv) If ΔABM and ΔCDM are similar, $CD = 6$ cm, $MD = 8$ cm and $BM = 24$ cm. Then find AB .
 - a. 17 cm
 - b. 18 cm
 - c. 12 cm
 - d. 24 cm
- v) In ΔABM , if $\angle BAM = 30^\circ$ then find $\angle MCD$
 - a. 40°
 - b. 45°

c. 60°

d. 30°

19. **Case study based -3**
POLYNOMIALS

Due to heavy storm an electric wire got bent as shown in the figure. It follows a mathematical shape. Answer the following questions below.

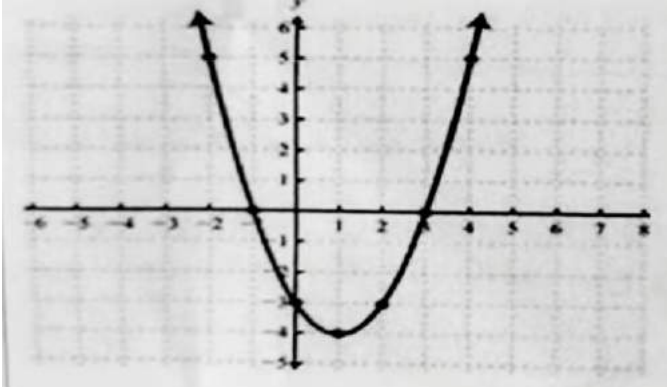

- i) Name the shape in which the wire is bent.
- Spiral
 - Ellipse
 - Linear
 - Parabola
- ii) How many zeroes are there for the polynomial (shape of the wire)?
- 2
 - 3
 - 1
 - 0
- iii) The zeroes of the polynomial are
- 1,5
 - 1,3
 - 3,5
 - 4,2
- iv) What will be the expression of the polynomial
- $x^2 + 2x - 3$
 - $x^2 - 2x + 3$
 - $x^2 - 2x - 3$
 - $x^2 + 2x + 3$
- v) What is the value of the polynomial if $x = -1$?
- 6
 - 18
 - 18

d. 0

20. **Case study based -4**
100 m RACE

A stopwatch was used to find the time that it took a group of students to run 100 m.



Time(in sec)	0-20	20-40	40-60	60-80	80-100
No. of students	8	10	13	6	3

- i) Estimate the mean time taken by a student to finish the race.
- a. 54 sec
 - b. 63 sec
 - c. 43 sec
 - d. 50 sec
- ii) What will be the upper limit of the modal class?
- a. 20
 - b. 40
 - c. 60
 - d. 80
- iii) The construction of cumulative frequency table is useful in determining the
- a. Mean
 - b. Median
 - c. Mode
 - d. None of the above
- iv) The sum of lower limits of median class and modal class is
- a. 60
 - b. 100
 - c. 80
 - d. 140
- v) How many students finished the race within 1 min?
- a. 18
 - b. 37
 - c. 31

PART – B**All questions are compulsory. In case of internal choices, attempt any one.****Section – III**

21. Mallica has 2 flowerbeds in her garden. One bed has 18 rows of plants and other has 24 rows of plants. Each of the beds has the same number of plants. What is the least number of plants in each flowerbed?
22. Find a point on Y-axis which is equidistant from the points (2,-2) and (-4,2)
OR
 Name the type of triangle formed by the points A (2,-2), B (-2, 1), C (5, 2). Justify your answer.
23. Find a quadratic polynomial whose zeroes are $5-3\sqrt{2}$ and $5+3\sqrt{2}$.
24. Construct a pair of tangents from a point 5cm away from the center of a circle of radius 3cm. Measure the lengths of the tangents.
25. If $\cos \theta = \frac{7}{25}$, find the value of $\tan \theta + \cot \theta$.
OR
 Calculate the value of θ if $(\sin \theta - 1)(2\cos \theta - 1) = 0$.
26. Prove that the parallelogram circumscribing a circle is a rhombus.

Section - IV

27. Prove that $3-\sqrt{5}$ is an irrational number, given that $\sqrt{5}$ is irrational.
28. If one zero of the polynomial $(a^2+9)x^2+13x+6a$ is reciprocal of the other. Find the value of a.
OR
 If α and β are the zeroes of the polynomial $f(x) = x^2-5x+k$ such that $\alpha - \beta = 1$, find the value of k.
29. Find the area of the shaded region in the given figure, where ABCD is a square of side 14 cm.

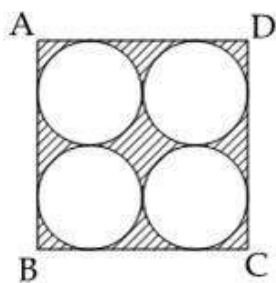

30. D is a point on the side BC of ΔABC , such that $\angle ADC = \angle BAC$. Prove that $AC^2 = BC \times CD$

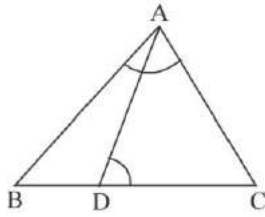

OR

In an equilateral ΔABC , D is a point on the side BC such that $BD = \frac{1}{3} BC$.
Prove that $9 AD^2 = 7AB^2$.

31. If the median of the distribution given below is 28.5, find the values of x and y.

Class interval	0-10	10-20	20-30	30-40	40-50	50-60	Total
Frequency	5	x	20	15	y	5	60

32. The angle of elevation of the top of a tower at a point on the horizontal line through the foot of the tower is 45° . After walking a distance of 80 m towards the foot of the tower along the same horizontal line, the angle of elevation of the top of the tower changes to 60° . Find the height of the tower.

33. Calculate the mode for the following frequency distribution.

Marks	0-10	10-20	20-30	30-40	40-50
No. of students	6	10	12	32	20

SECTION - V

34. The angle of elevation of the top of a building from the foot of a tower is 30° and the angle of elevation of the top of the tower from the foot of the building is 60° . If the tower is 50 m high, find the height of the building.

OR

As observed from the top of a 75m high lighthouse from the sea level, the angles of depression of two ships are 30° and 45° . If one ship is exactly behind the other on the same side of the light house, find the distance between the two ships.

35. Water in a canal, 6 m wide and 1.5 m deep is flowing with a speed of 10 km/hr. How much area will it irrigate in 30 min, if 8 cm of standing water is needed?
36. A boat goes 30 km upstream and 44 km down-stream in 10 hrs. In 13 hrs, it can go 40 km upstream and 55 km down-stream. Determine the speed of the stream and that of the boat in still water.

HINTS & SOLUTIONS

Maths Sample paper

1. 1650 OR 4
2. $k = 0$
3. $k \neq 6$
4. $a = 3, b = 1$
5. -320 OR $5n - 12$
6. $k = -7$
7. $D < 0$ OR $k = 8$
8. $\angle OPA = 30^\circ$ OR 50°
9. $QR = 7.6$ cm
10. $x = 1$
11. $\sqrt{119}$ cm
12. 75°
13. $k = 1$
14. 22 cm
15. 2 cm
16. $\frac{1}{2}$ OR $\frac{1}{26}$
17. (i) (d) (6, 5)
(ii) (b) $3\sqrt{2}$ units
(iii) (d) Sita & Rita
(iv) (a) Square
(v) (b) 6 units
18. (i) (d) None of these
(ii) (c) AA
(iii) (a) 3 m
(iv) (b) 18 cm
(v) (d) 30°



19. (i) (d) Parabola

(ii) (a) 2

(iii) (b) -1, 3

(iv) (c) $x^2 - 2x - 3$

(v) (d) 0

20. (i) (c) 43 sec

(ii) (c) 60

(iii) (b) Median

(iv) (c) 80

(v) (c) 31

21. Number of rows in first flower bed = 18

Number of rows in second flower bed = 24

To find:

The least number of plants in each flower bed.

Solution:

Since Mallika has 18 rows of plants in one flower bed and 24 in the other.

To find least number of flowers in both flower beds we need to find the LCM of 18 and 24.

$$18 = 2 \cdot 3 \cdot 3$$

$$24 = 2 \cdot 2 \cdot 2 \cdot 3$$

So, taking the LCM of 18 and 24 will be $2 \cdot 2 \cdot 2 \cdot 3 \cdot 3$, hence we would get 72.

Therefore, Least number of flowers in both flower beds should be 72.

22. Let $P(x,0)$ be a point on X-axis

$$PA = PB$$

$$PA^2 = PB^2$$

$$(x - 2)^2 + (0 + 2)^2 = (x + 4)^2 + (0 - 2)^2$$

$$x^2 + 4 - 4x + 4$$



$$= x^2 + 16 + 8x + 4$$

$$-4x + 4 = 8x + 16$$

$$x = -1 \rightarrow P(-1, 0)$$

OR

Isosceles triangle as the distances are $5\sqrt{2}$, 5 and 5 units.

23. Given zeros are

$$5 + 3\sqrt{2} \text{ and } 5 - 3\sqrt{2}$$

Sum of the zeros:

$$= 5 + 3\sqrt{2} + 5 - 3\sqrt{2}$$

$$= 10$$

Product of the zeros:

$$= (5 + 3\sqrt{2})(5 - 3\sqrt{2})$$

$$= 5^2 - (3\sqrt{2})^2$$

$$= 25 - 18$$

$$= 7$$

The required quadratic polynomial is

$$x^2 - (\text{sum of the zeros})x + \text{product of the zeros}$$

$$x^2 - 10x + 7$$

\therefore The quadratic polynomial is $x^2 - 10x + 7$

24. Given, a circle of radius 3 cm whose Centre is O and a point P, 5 cm away from its centre.

STEPS OF CONSTRUCTION:

1. Draw circle with O as centre and radius = 3 cm. Take a point P such that $OP = 5$ cm.
2. Draw the bisector of OP which intersect OP at M.
3. Taking M as centre and MO as radius, draw a dotted circle. Let this circle cuts the given circuit A and B.
4. Join PA & PB.



5. Thus, PA & PB are the required tangents. By measurement using scale
 $PA = PB = 4$ cm.

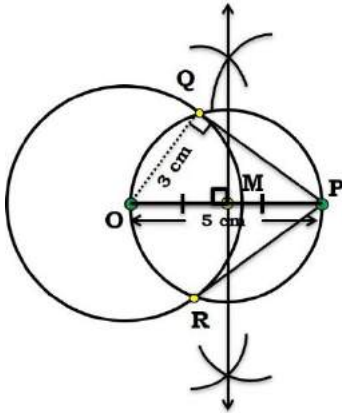

25. if $\cos \theta = 7/25$

$\tan \theta = 24/7$ and $\cot \theta = 7/24$

$\tan \theta + \cot \theta = 24/7 + 7/24 = 625/168$

OR

$\sin \theta = 1$ or $\cos \theta = 1/2$

$\theta = 90^\circ$ or 60°

26. Since ABCD is a parallelogram,

$AB = CD \dots(1)$

$BC = AD \dots(2)$

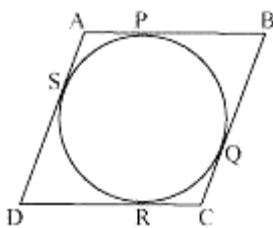

It can be observed that

$DR = DS$ (Tangents on the circle from point D)

$CR = CQ$ (Tangents on the circle from point C)

$BP = BQ$ (Tangents on the circle from point B)

$AP = AS$ (Tangents on the circle from point A)

Adding all these equations, we obtain

$$DR + CR + BP + AP = DS + CQ + BQ + AS$$

$$(DR + CR) + (BP + AP) = (DS + AS) + (CQ + BQ)$$

$$CD + AB = AD + BC$$

On putting the values of equations (1) and (2) in this equation, we obtain

$$2AB = 2BC$$

$$AB = BC \dots(3)$$

Comparing equations (1), (2), and (3), we obtain

$$AB = BC = CD = DA$$

Hence, ABCD is a rhombus.

27. If we are known that $\sqrt{5}$ is irrational than it can be proved as:

Let $3 - \sqrt{5}$ be a rational number

$3 - \sqrt{5} = p/q$ [where p and q are integers , $q \neq 0$ and q and p are co-prime numbers]

$$\sqrt{5} = 3 - p/q$$

$$\sqrt{5} = (3q - p)/q$$

We know that number of form p/q is a rational number.

So, $\sqrt{5}$ is also a rational number.

But we know that $\sqrt{5}$ is irrational number. This contradicts our assumption.

Therefore, $3 - \sqrt{5}$ is an irrational number.



28.

The given quadratic polynomial is $(a^2 + 9)x^2 + 13x + 6a$.

Let one zero of the quadratic polynomial be α .

\therefore The other zero of the quadratic polynomial is $\frac{1}{\alpha}$.

$$\text{Product of zeroes} = \alpha \times \frac{1}{\alpha} = 1$$

$$\frac{6a}{a^2 + 9} = 1 \quad \left(\text{Product of zeroes} = \frac{\text{Constant term}}{\text{Coefficient of } x^2} \right)$$

$$6a = a^2 + 9$$

$$a^2 - 6a + 9 = 0$$

$$(a - 3)^2 = 0$$

$$a - 3 = 0$$

$$a = 3$$

Thus, the value of a is 3.

OR

$$x^2 - 5x + k$$

Here, $a = 1$, $b = -5$ and $c = k$

$$\text{Now, } \alpha + \beta = -b/a = -(-5)/1 = 5$$

$$\alpha * \beta = c/a = k/1 = k$$

$$\text{Now, } \alpha - \beta = 1$$

Squaring both sides, we get,

$$(\alpha - \beta)^2 = 1^2$$

$$\Rightarrow \alpha^2 + \beta^2 - 2\alpha\beta = 1$$

$$\Rightarrow (\alpha^2 + \beta^2 + 2\alpha\beta) - 4\alpha\beta = 1$$

$$\Rightarrow (\alpha + \beta)^2 - 4\alpha\beta = 1$$

$$\Rightarrow (5)^2 - 4k = 1$$

$$\Rightarrow -4k = 1 - 25$$

$$\Rightarrow -4k = -24$$

$$\Rightarrow k = 6 \text{ So the value of } k \text{ is } 6.$$

7



29. Area of Square ABCD = $14 \times 14 \text{ cm}^2 = 196 \text{ cm}^2$

Diameter of each Circle = $\frac{14}{2} \text{ cm} = 7 \text{ cm}$

Radius of each Circle = $\frac{7}{2} \text{ cm}$

Area of one Circle = $\pi r^2 = \frac{154}{4} = \frac{77}{2} \text{ cm}^2$

Area of Four Circles = 154 cm^2

Area of Shaded Region

Area of Shaded Region = Area of Square ABCD - Area of four Circles

= $(196 - 154) \text{ cm}^2 = 42 \text{ cm}^2$

30. In $\triangle ADC$ and $\triangle BAC$,

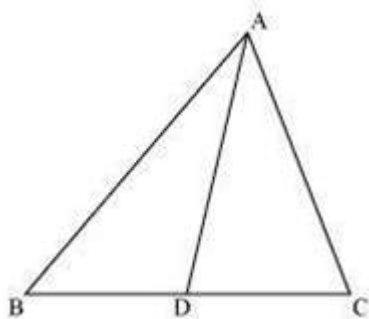

To Prove: $CA^2 = CB \cdot CD$

Given: $\angle ADC = \angle BAC$

Proof: Now In $\triangle ADC$ and $\triangle BAC$,

$\angle ADC = \angle BAC$

$\angle ACD = \angle BCA$ (Common angle)

According to AA similarity, if two corresponding angles of two triangles are equal then the triangles are similar

$\triangle ADC \sim \triangle BAC$ (By AA similarity)

We know that corresponding sides of similar triangles are in proportion

Hence in $\triangle ADC$ and $\triangle BAC$,

$$\frac{CA}{CB} = \frac{CD}{CA}$$

$$CA^2 = CB \times CD$$

Hence Proved

OR

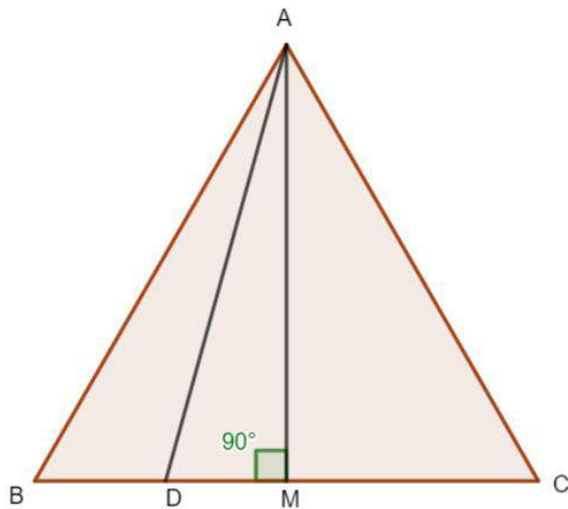

Given: $BD = BC/3$

To Prove: $9 AD^2 = 7 AB^2$

Proof:

Let the side of the equilateral triangle be a , and AM be the altitude of $\triangle ABC$

$BM = MC = BC/2 = a/2$ [Altitude of an equilateral triangle bisect the side]

And, then, in $\triangle ABM$, by pythagoras theorem we write,
Pythagoras Theorem : Square of the Hypotenuse equals to the sum of the squares of other two sides.

$$AM^2 = AB^2 - BM^2$$

$$\text{or } AM^2 = a^2 - a^2/4$$

$$AM^2 = \frac{4a^2 - a^2}{4} = \frac{3a^2}{4}$$

$$AM = \frac{a\sqrt{3}}{2}$$

$$BD = a/3 \quad [BC = a]$$

$$DM = BM - BD$$

$$= a/2 - a/3$$

$$= a/6$$



According to pythagoras theorem in a right angled triangle, (hypotenuse)² = (altitude)² + (base)²

Applying Pythagoras theorem in ΔADM , we obtain

$$AD^2 = AM^2 + DM^2$$

$$AD^2 = \left(\frac{a\sqrt{3}}{2}\right)^2 + \left(\frac{a}{6}\right)^2$$

$$AD^2 = \frac{3a^2}{4} + \frac{a^2}{36}$$

$$AD^2 = \frac{27a^2 + a^2}{36}$$

$$AD^2 = \frac{28a^2}{36}$$

Now, $a = AB$ or $a^2 = AB^2$

$$AD^2 = \frac{28AB^2}{36}$$

$$36 AD^2 = 28 AB^2$$

$$9 AD^2 = 7 AB^2$$

Hence, Proved

31. Let's make a cumulative frequency table for the above problem

Class Interval	frequency	Cumulative frequency
0-10	5	5
10-20	x	5+x
20-30	20	x + 25
30-40	15	40 + x
40-50	y	40 + x + y
50-60	5	45 + x + y
Total	45 + x + y = 60	

Total frequency, $N = 60$

$$\frac{N}{2} = 30$$

Now,

Given median = 28.5, lies in 20 - 30

Median class = 20-30

frequency corresponding to median class, $f = 20$

cumulative frequency of the class preceding the median class, $cf = 5 +$

x Lower limit, $l = 20$

class height, $h = 10$

Now,

Median can be calculated as:

$$\text{Median} = l + \left(\frac{\frac{n}{2} - cf}{f} \right) \times h$$

$$28.5 = 20 + \left(\frac{30 - 5 - x}{20} \right) \times 10$$

$$28.5 - 20 = \frac{25 - x}{2}$$

$$8.5 = \frac{25 - x}{2}$$

$$25 - x = 8.5 \times 2$$

$$\Rightarrow 25 - x = 17$$

$$\Rightarrow x = 25 - 17$$

$$\Rightarrow x = 8$$

Now,

From the cumulative frequency we can find the value of $x + y$ as:

$$45 + x + y = 60$$

$$\Rightarrow x + y = 60 - 45$$

$$\Rightarrow x + y = 15$$

$$\Rightarrow y = 15 - x$$

$$\text{as, } x = 8$$

$$\Rightarrow y = 15 - 8$$

$$\Rightarrow y = 7$$

Hence,

Value of $x = 8$ and $y = 7$

32.

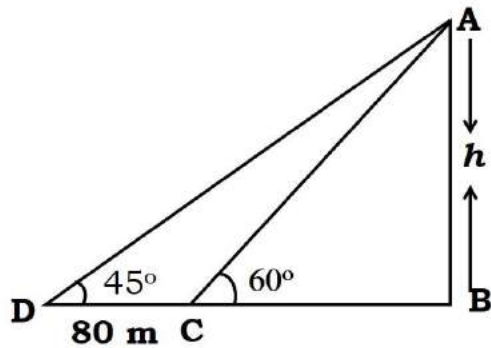

In $\triangle ABC$,

$$AB/BC = \tan 60^\circ$$

$$h/BC = \sqrt{3}$$

$$BC = h/\sqrt{3}$$

In $\triangle ABD$,

$$AB/BD = \tan 45^\circ$$

$$h/(BC + 80) = 1$$

$$BC + 80 = h$$

$$h/\sqrt{3} + 80 = h$$

$$h = 12 + 4\sqrt{3} \text{ m}$$

33.

Marks	Number of Students
0 - 10	6
10 - 20	10
20 - 30	12
30 - 40	32
40 - 50	20

Modal class = 30 - 40

$L = 30$

12



$$f_1 = 32, f_0 = 12, f_2 = 20$$

$$\text{Mode} = 30 + \frac{32-12}{2(32)-12-20} = 30.625$$

34.

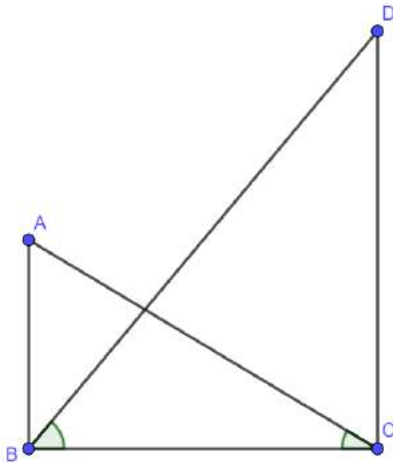

Let us take AB as building and Let us take DC as tower = 50 m,

$$\angle ACB = 30^\circ$$

And,

$$\angle DBC = 60^\circ;$$

$$AB = ?$$

In ΔDCB ;

$$\tan \theta = \frac{p}{b}$$

where, p = perpendicular and b = base

$$\tan 60^\circ = \frac{50}{b}$$

$$\sqrt{3} = \frac{50}{b}$$

$$b = \frac{50}{\sqrt{3}}$$

In ΔACB



$$\tan \theta = \frac{p}{b}$$

where p = perpendicular and b = base

$$\tan 30^\circ = \frac{AB}{b}$$

$$\frac{1}{\sqrt{3}} = \frac{50}{\sqrt{3}}$$

$$AB = \frac{50}{\sqrt{3} \times \sqrt{3}}$$

$$AB = 16.67 \text{ m}$$

OR

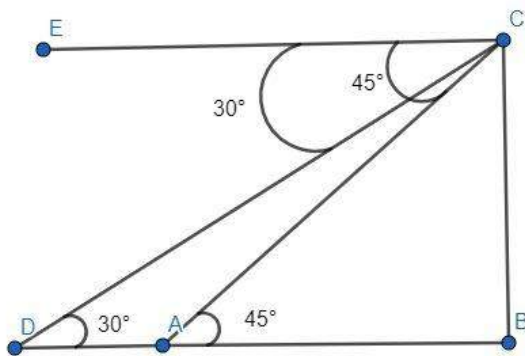

A and D are the two ships and the distance between the ships is AD. BC is the lighthouse and is the height of the lighthouse. observer is at point C
Given: BC = height of lighthouse = 75m

$$\angle CAB = 45^\circ,$$

$$\angle CDB = 30^\circ$$

To Find: DA

In ΔABC ,

$$\tan \theta = \frac{p}{b}$$

[p = perpendicular and b = base of the right angled triangle]

$$\tan(45^\circ) = \frac{75}{AB}$$

$$AB = 75 \text{ m}$$

$$[\tan 45^\circ = 1]$$

In ΔCDB ,

$$\tan \theta = \frac{p}{b}$$

$$\tan 30^\circ = \frac{75}{BD}$$

$$\frac{1}{\sqrt{3}} = \frac{75}{BD}$$

$$BD = 75\sqrt{3} \text{ m}$$

$$AD + AB = 75\sqrt{3} \text{ m}$$

$$DA = 75\sqrt{3} - 75$$

$$DA = 75(\sqrt{3} - 1) \text{ m}$$

Hence the distance between the ships is $75(\sqrt{3} - 1) \text{ m}$

35.

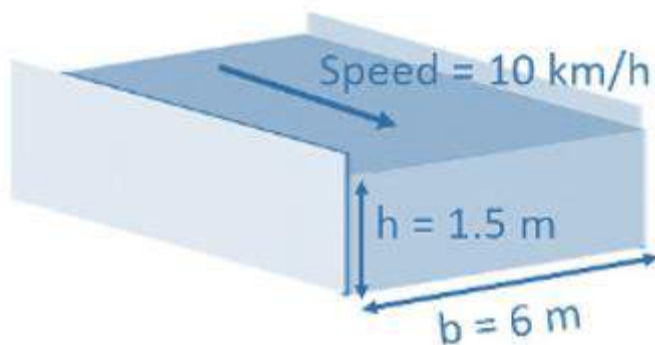

$$\text{Area of cross-section} = 6 \times 1.5 = 9 \text{ m}^2$$

$$\text{Speed of water} = 10 \text{ km/h}$$

$$\text{Water flows through canal in 60 min} = 10 \text{ km}$$

$$\text{Water flows through canal in 1 min} = \frac{1}{60} \times 10 \text{ km}$$

$$\text{Water flows through canal in 30 min} = \frac{30}{60} \times 10 \text{ km}$$

$= 5 \text{ km} = 5000 \text{ m}$ Hence length of the canal is 5000 m. The volume of canal = $L \times B \times H = (5000 \times 6 \times 1.5) = 45000 \text{ m}^3$

Let the irrigated area be A.

Now, we know that,

The volume of water irrigating the required area will be equal to the volume of water that flowed in 30 minutes from the canal.

Vol. of water flowing in 30 minutes from canal = Vol. of water irrigating the reqd. area

$$\Rightarrow 45000 = \text{Area} \times \text{height}$$

$$\text{Given height} = 8 \text{ cm} = 0.08 \text{ m} \Rightarrow 45000 = \text{Area} \times 0.08$$

$$\Rightarrow \text{Area} = \frac{45000}{0.08}$$

$$\text{Area} = 562500 \text{ m}^2$$

36. Let speed of boat in still water be x km/h and speed of stream be y km/h.

Speed upstream = $(x - y)$ km/h

Speed downstream = $(x + y)$ km/h

$$\text{Let } \frac{1}{x - y} = a \text{ and } \frac{1}{x + y} = b$$

$$\frac{30}{x - y} + \frac{44}{x + y} = 10 \Rightarrow 30a + 44b = 10 \Rightarrow 120a + 176b = 40$$

$$\frac{40}{x - y} + \frac{55}{x + y} = 13 \Rightarrow 40a + 55b = 13 \Rightarrow 120a + 165b = 39$$

On subtracting, we get,

$$b = \frac{1}{11}$$

$$\therefore 30a + 4 = 10 \Rightarrow 30a = 6 \Rightarrow a = \frac{1}{5}$$

$$\therefore x - y = 5 \text{ and } x + y = 11$$

On solving, we get,

$$x = 8, \quad y = 3$$

\therefore Speed of boat in still water = 8 km/h

And, Speed of stream = 3 km/h
